

SSOP24: plastic shrink small outline package; 24 leads; body width 3.9 mm; lead pitch 0.635 mm SOT556-1

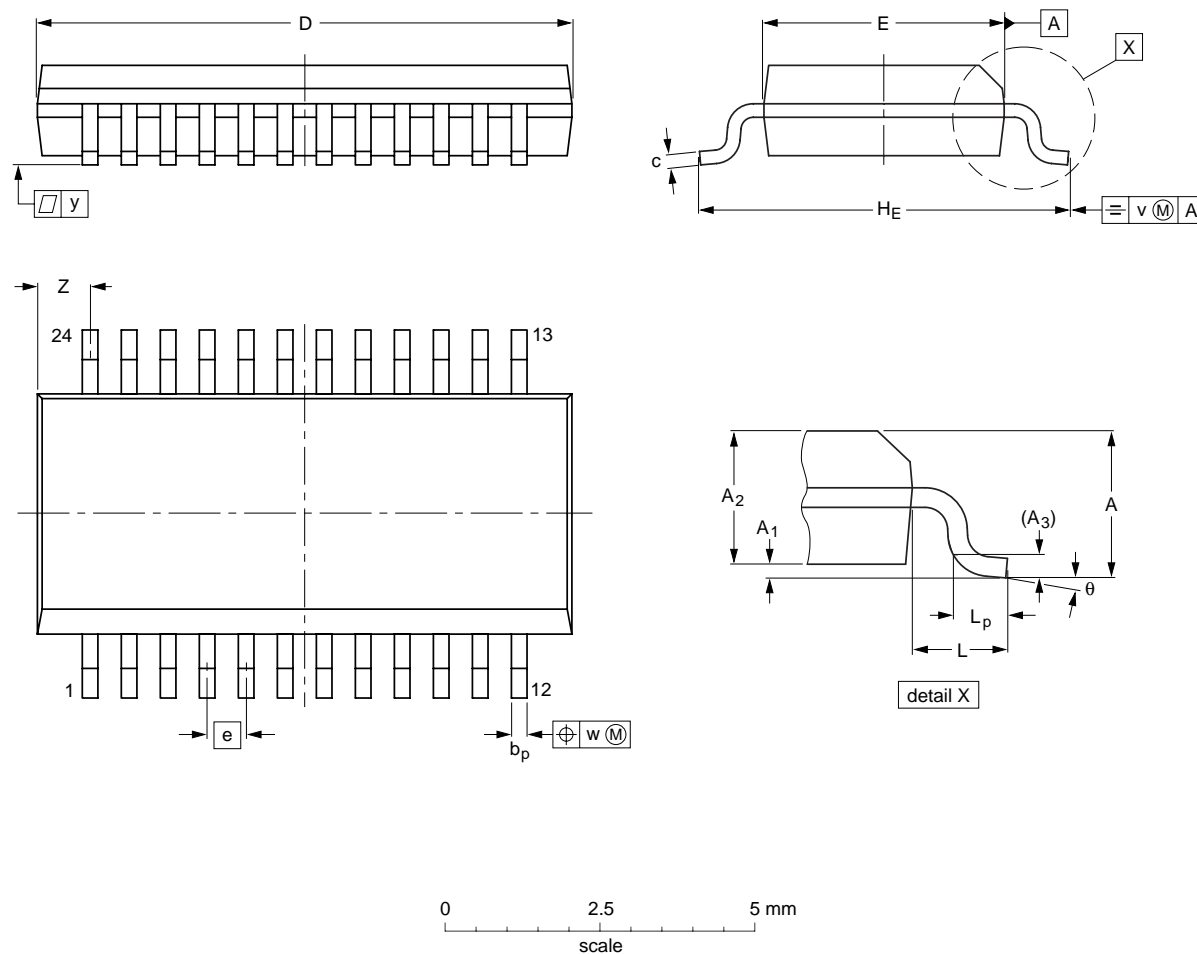

**DIMENSIONS (millimetre dimensions are derived from the original inch dimensions)**

| UNIT   | A max. | A <sub>1</sub>   | A <sub>2</sub> | A <sub>3</sub> | b <sub>p</sub> | c                | D <sup>(1)</sup> | E <sup>(1)</sup> | e     | H <sub>E</sub> | L     | L <sub>p</sub> | v    | w     | y     | Z <sup>(1)</sup> | θ        |
|--------|--------|------------------|----------------|----------------|----------------|------------------|------------------|------------------|-------|----------------|-------|----------------|------|-------|-------|------------------|----------|
| mm     | 1.73   | 0.25<br>0.10     | 1.55<br>1.40   | 0.25           | 0.31<br>0.20   | 0.25<br>0.18     | 8.8<br>8.6       | 4.0<br>3.8       | 0.635 | 6.2<br>5.8     | 1     | 0.89<br>0.41   | 0.25 | 0.18  | 0.1   | 1.05<br>0.66     | 8°<br>0° |
| inches | 0.068  | 0.0098<br>0.0040 | 0.061<br>0.055 | 0.01           | 0.012<br>0.008 | 0.0098<br>0.0075 | 0.344<br>0.337   | 0.157<br>0.150   | 0.025 | 0.244<br>0.228 | 0.041 | 0.035<br>0.016 | 0.01 | 0.007 | 0.004 | 0.040<br>0.026   | 8°<br>0° |

**Note**

1. Plastic or metal protrusions of 0.2 mm (0.008 inch) maximum per side are not included.

| OUTLINE VERSION | REFERENCES |        |       | EUROPEAN PROJECTION | ISSUE DATE           |
|-----------------|------------|--------|-------|---------------------|----------------------|
|                 | IEC        | JEDEC  | JEITA |                     |                      |
| SOT556-1        |            | MO-137 |       |                     | 99-12-27<br>03-02-18 |